

# STF60-103-6.0-ER32

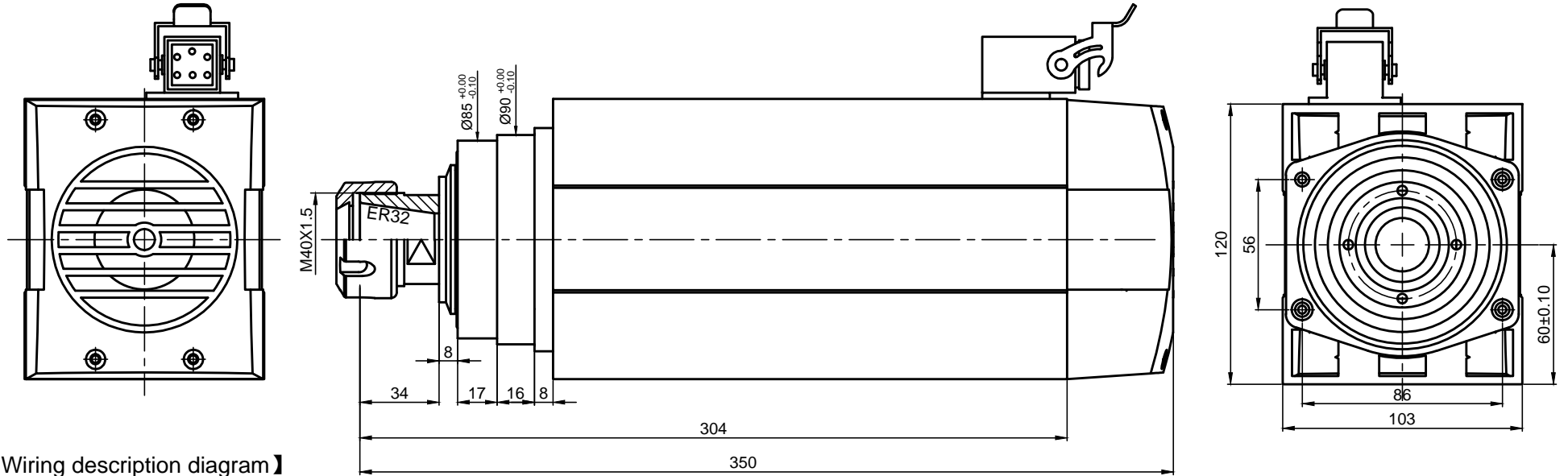

【Wiring description diagram】

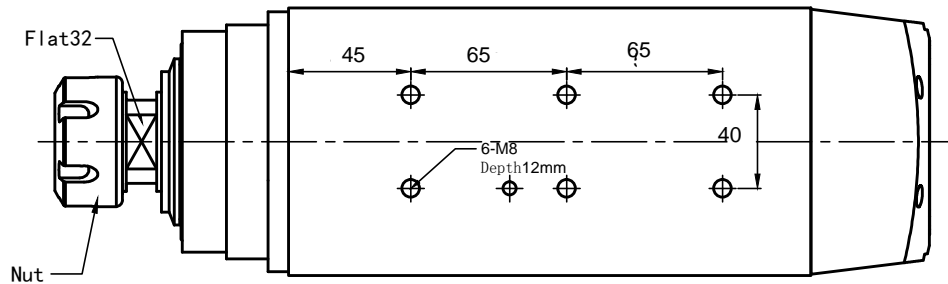
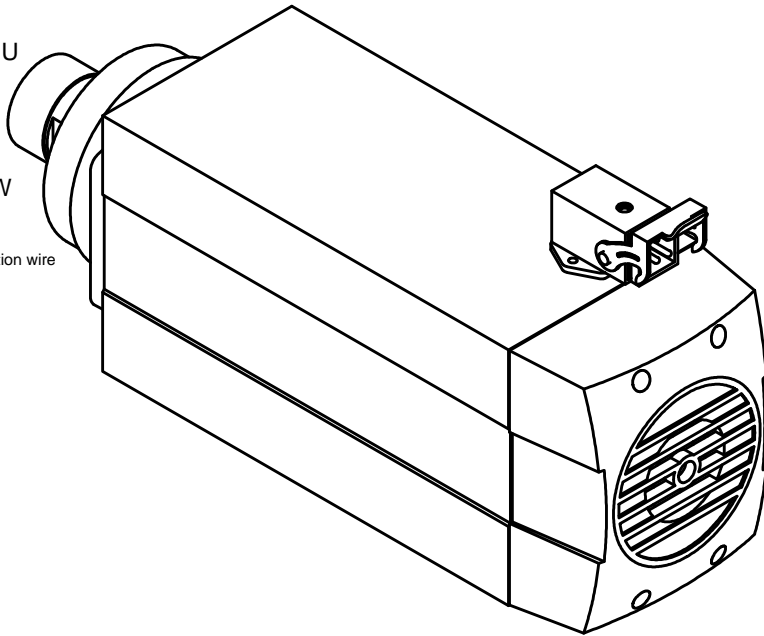
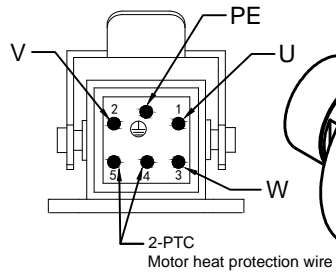

【CAUTION】

- Rotating mode: anticlockwise from the shaft extension end

PTC single-core thermistor parameter	
DC power supply	Maximum DC25V/100mA
-20~25℃	≤100Ω
≤90℃	≤250Ω
105℃	≤550Ω
110℃	Rated operating temperature
115℃	≥1330Ω
≥125℃	≥4KΩ
≤160℃	Maximum storage temperature

WHD SPINDLE MOTOR							
Power	Voltage	Current	Shaft	Frequency	Speed	Cool	Weight
6.0KW	380V	12.8A	ER32	300Hz	18000RPM	Air	14KG